



Designation: D1781 – 98 (Reapproved 2004)

Standard Test Method for Climbing Drum Peel for Adhesives¹

This standard is issued under the fixed designation D1781; the number immediately following the designation indicates the year of original adoption or, in the case of revision, the year of last revision. A number in parentheses indicates the year of last reapproval. A superscript epsilon (ϵ) indicates an editorial change since the last revision or reapproval.

This standard has been approved for use by agencies of the Department of Defense.

1. Scope

1.1 This test method covers the determination of the peel resistance of adhesive bonds between: a relatively flexible adherend and a rigid adherend; and the relatively flexible facing of a sandwich structure and its core, when tested under specified conditions.

1.2 The values stated in SI units are to be regarded as the standard. The values given in parentheses are for information only.

1.3 *This standard does not purport to address all of the safety concerns, if any, associated with its use. It is the responsibility of the user of this standard to establish appropriate safety and health practices and determine the applicability of regulatory limitations prior to use.*

2. Referenced Documents

2.1 *ASTM Standards:*²

[B209 Specification for Aluminum and Aluminum-Alloy Sheet and Plate](#)

[D907 Terminology of Adhesives](#)

[E4 Practices for Force Verification of Testing Machines](#)

2.2 *ASTM Adjuncts:*

Climbing Drum Peel Tester³

¹ This test method is under the jurisdiction of ASTM Committee D14 on Adhesives and is under the jurisdiction of Subcommittee D14.80 on Metal Bonding Adhesives.

Current edition approved April 1, 2004. Published April 2004. Originally approved in 1960. Last previous edition approved in 1998 as D1781 – 98. DOI: 10.1520/D1781-98R04.

² For referenced ASTM standards, visit the ASTM website, www.astm.org, or contact ASTM Customer Service at service@astm.org. For *Annual Book of ASTM Standards* volume information, refer to the standard's Document Summary page on the ASTM website.

³ Detailed working drawings for the apparatus illustrated are available from ASTM International, 100 Barr Harbor Drive, West Conshohocken PA 19428-2959. Request [ADJD1781](#).

3. Terminology

3.1 *Definitions*—Many of the terms used in this test method are defined in Terminology [D907](#).

4. Summary of Test Method

4.1 Determine the peeling force of a conditioned adhesive bonded sandwich assembly by peeling a face skin around a circular drum. This is done by clamping the assembly in a universal test machine. The average peeling load is determined using a standard formula.

5. Significance and Use

5.1 This test method may be used to determine comparative rather than fundamental measurements of adhesion and is particularly suitable for process control, some examples of which are listed.

5.1.1 This test method is particularly sensitive to adherend surface preparation and is of value where the adhesive is used in conjunction with a primer.

5.1.2 When a relatively brittle adhesive is used, the peel resistance can often give an indication of the degree of cure, that is, higher values than normally realized may indicate an incomplete cure. Direct comparison of different adhesives or processes can only be made when specimen design and test conditions are identical.

6. Apparatus

6.1 *Peeling Apparatus*, consisting of a flanged drum, flexible loading straps or cables, and suitable clamps for holding the test specimen. The apparatus illustrated in [Fig. 1](#) has been found to be satisfactory.

6.1.1 The outside radius of the drum is 51.00 ± 0.13 mm (2.000 ± 0.005 in.), and the radius of the flange, including one half of the thickness of the loading straps or cables, is 12.70 ± 0.13 mm (0.500 ± 0.005 in.) larger than the radius of the drum.

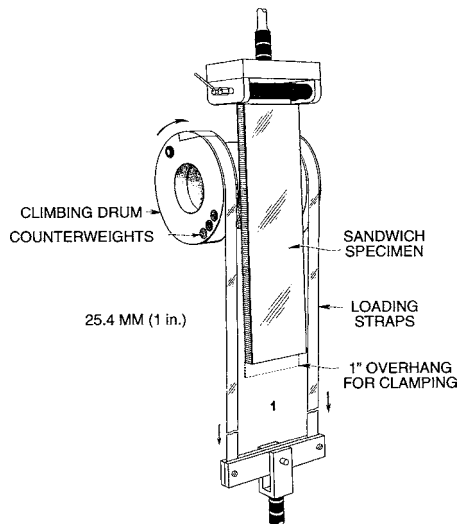

FIG. 1 Assembly of Peeling Apparatus

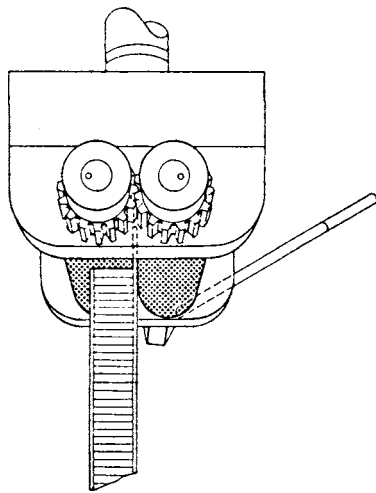

FIG. 2 Top Clamp

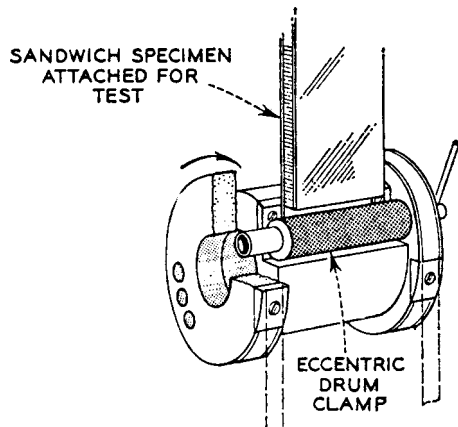

FIG. 3 Drum Clamp

6.1.2 Use a suitable top clamp (Fig. 2) for supporting the specimen, and a drum clamp (Fig. 3) to hold the adherend against the face of the drum.

6.1.3 Balance the drum about the axis by the use of counterweights (as shown in Fig. 1) placed diametrically opposite the drum clamp to compensate for the weight of this clamp.

6.1.4 The drum and flanges with the drum clamp and its compensating weight weighs ≤ 3.6 kg (8 lb), a lighter weight being preferable to facilitate handling of the apparatus.^{4,3}

6.2 *Testing Machine*, capable of applying tensile loads under the conditions prescribed in Section 11 and with the following further requirements:

6.2.1 The rate of movement between heads of the testing machine remains essentially constant under fluctuating loads (Note 1).

6.2.2 The testing machine weighs the load to within 1 %. The testing machine and range are selected such that the maximum load on the specimen falls between 15 and 85 % of the full-scale capacity.

6.2.3 The use of autographic equipment to record load versus head movement is recommended.

6.2.4 Verification of the testing machine is made in accordance with the recommendations of Practices E4.

NOTE 1—It is difficult to meet this requirement when loads are measured with a spring-type or pendulum-type weighing device.

7. Test Specimen

7.1 For evaluation of adhesives in laminated assemblies, a specimen of the type shown in Fig. 4 has been found to be satisfactory. The specimen is 25 mm (1 in.) wide between saw kerfs and at least 254 mm (10 in.) long. The specimen may be cut from larger bonded panels if desired.

7.2 For evaluation of adhesives in sandwich constructions, make the test specimens in conformance to the general form of the specimen shown in Fig. 1. The specimen is 76 mm (3 in.) wide by at least 305 mm (12 in.) long, including about a 25-mm (1-in.) overhang of one facing at each end. Thickness of the core is not important, except in the sense that the sandwich specimen does not bend while the facing is being peeled. For comparative evaluation of adhesives in bonding metal-faced sandwich constructions, a facing of clad aluminum alloy meeting the requirements of Specification B209, Alloy 2024-T3, 0.51 mm (0.020 in.) thick with a core 12.7 mm (0.5 in.) thick, has been found to be suitable. Other metal facings of comparable flexibility may also be used. The specimens may be cut from larger bonded panels if desired.

NOTE 2—Direct comparisons of different adhesives can be made only when specimen design and test conditions are identical.

7.3 Test at least six specimens, for example, two or more from each of three bonded panels, for each adhesive sample.

7.4 For sandwich constructions based on orthotropic cores, peel half of the specimens parallel to the length direction of the

This 12.70 ± 0.13 mm (0.500 ± 0.005 in.) less half the thickness of the adherend to be peeled, is the effective torque arm of the apparatus.

⁴ A suitable climbing drum peel apparatus is available from Custom Scientific Instruments, Inc., 13 Wing Drive, Whippany, NJ, 07981.